



HYCD-319A

Combined Refrigerator and Freezer

Scope of Application

This product is designed to store frozen plasma, biological materials, vaccines, chemical products, electronic devices and for low temperature storage of special materials, in blood banks, hospitals, clinics, universities, research institutes, industrial and other laboratories.

Innovative Design

- Intelligent microprocessor with digital display
- Audible and visual alert with remote alarm contacts
- Comply with NSF/ANSI456 certification
- Natural Hydrocarbon refrigerant
- Self-closing door with magnetic gasket
- Stainless steel interior
- Padlock hasp for secure storage

Product Advantages



Multipurpose and Space Efficient

- One cabinet with two independent chambers, both are self-contained and independently controlled with individual doors
- Refrigerator chamber is equipped with a double-paned glass viewing window and LED interior lighting



Environment Friendly

Hydrocarbon refrigerant (R600a for refrigerator / R290 for freezer) and CFC-free polyurethane insulation for reduced global warming potential



Stainless Steel Interior

The interior of refrigerator and freezer are both made of stainless steel, which is easy to clean and corrosion-proof



Microprocessor Controller with Digital Display

- Refrigerator temperature 2-8°C with resolution of 0.1°C
- Freezer temperature -40--15°C with resolution of 1°C
- Multiple alarm functions with remote alarm contact to ensure safe monitoring



High Performance

- Refrigerator: Forced-air cooling system with cycle defrost, temperature uniformity $\pm 3^{\circ}\text{C}$
- Freezer: Cold wall cooling system, manual defrost, temperature uniformity $\pm 5^{\circ}\text{C}$
- Standard USB port & optional printer, easy to get temperature record

Ergonomic Design



Equipped with padlocks in both refrigerator and freezer to ensure storage safety



Equipped with electrically heated glass to prevent condensation effectively



Two test holes for both refrigerator and freezer as standard, allow independent testing of cabinet temperature



Refrigerator and freezer are equipped with self-closing hinges to avoid door ajar (less than 90° self-closing)

Product Parts



Microprocessor controller with resolution of 0.1°C for refrigerator and 1°C for freezer

Optional printer can print temperature data

USB interface for easier data transfer

NSF Barrier

Equipped with LED lights in the refrigerator

Dual fan system providing high refrigeration efficiency with a better temperature uniformity and stability

Magnetic gasket for positive seal

Equipped with 3 stainless steel shelves in the refrigerator

Electronic heating glass door for refrigerator

Equipped with 1 stainless steel drawer in refrigerator

Stainless steel

Stainless steel shelf (For supporting the upper drawer)

Built-in door handle

Equipped with 2 ABS drawers in the freezer

Four casters and two levelling legs for ease of maneuvering and positioning

Product Performance



Refrigerator Cool Down Curve

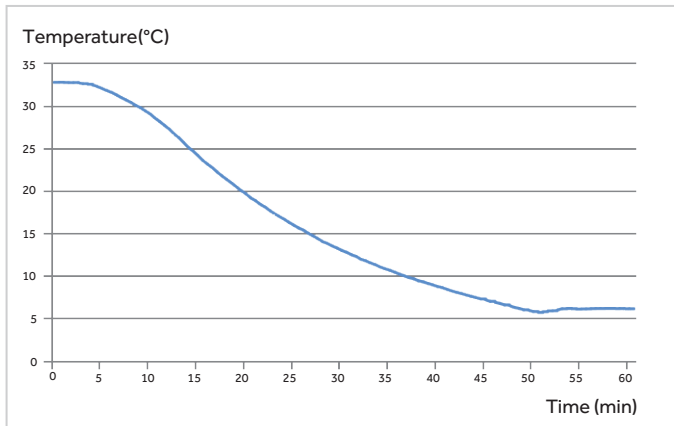

Freezer Cool Down Curve

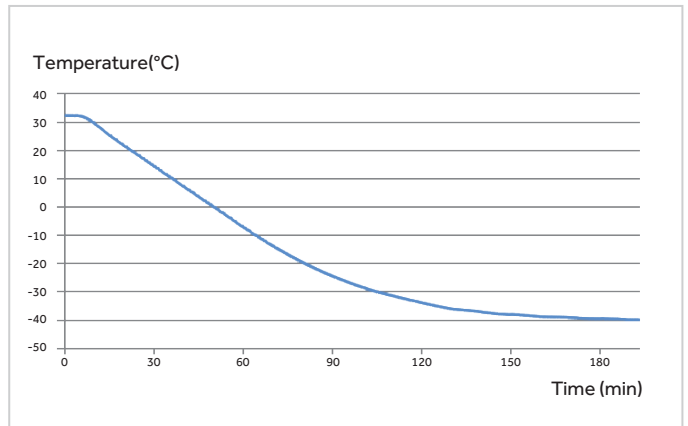

Refrigerator Stability Curve

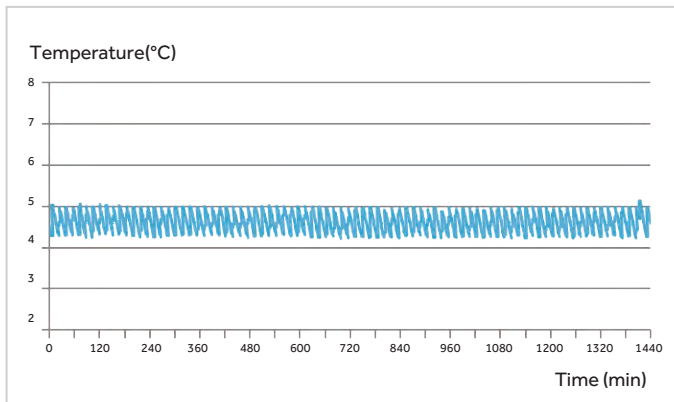

Freezer Stability Curve

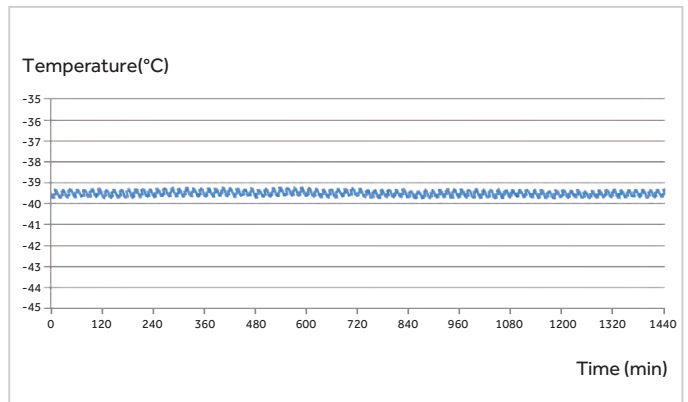

Dimensions

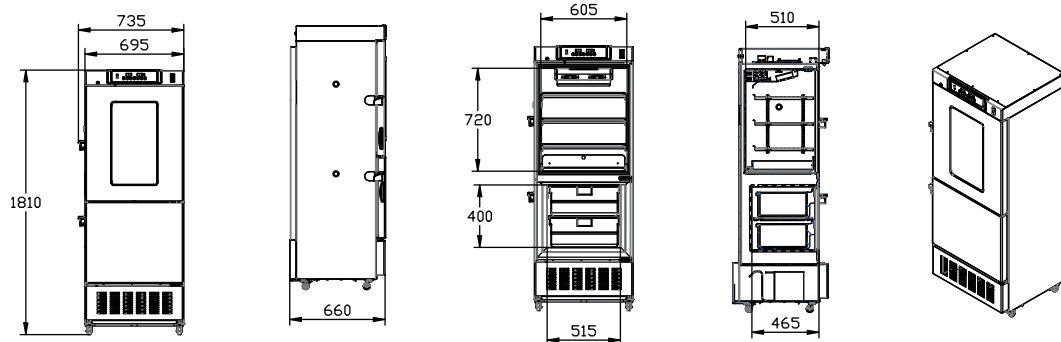



Model		HYCD-319A	
Technical Data	Cabinet Type	Upright	
	Climate Class	N	
	Cooling Type	Refrigerator: Forced air cooling Freezer: Direct cooling	
	Defrost Mode	Refrigerator: Auto/ Freezer: Manual	
	Refrigerant	Refrigerator: R600a 45g/ Freezer: R290 60g	
	Sound Level (dB(A))	50	
Performance	Temperature Range (°C)	Refrigerator: 2~8 / Freezer: -15~-40	
Control	Controller	Microprocessor	
	Display	LED	
Electrical Data	Power Supply (V/Hz)	115/60	
	Electrical Current (A)	6	
Dimensions	Capacity (L/Cu.Ft)	Refrigerator: 200/7.06; Freezer: 100/3.53	
	Net/Gross Weight (approx)	kg	145/160
		lbs	319.7/352.7
	Interior Dimensions (W*D*H)	mm	Refrigerator: 605*510*720 Freezer: 515*465*440
		in	Refrigerator: 23.8*20*28.3 Freezer: 20.2*18.3*17.3
	Exterior Dimensions (W*D*H)	mm	735*660*1810
		in	28.9*26.0*71.3
	Packing Dimensions (W*D*H)	mm	775*720*1930
		in	30.5*28.3*76
Container Load (20'/40'/40'H)	21/43/43		
Alarms	High/Low Temperature	Y	
	Sensor Error	Y	
	Power Failure	Y	
	Door Ajar	Y	
	High Ambient Temp	Y	
	Low Battery	Y	
	Remote Alarm	Y	
Accessories	Caster	Y/4	
	Foot	Y/2	
	Porthole	Y/2	
	Shelves/Drawers	Refrigerator: 3/1; Freezer: 1 (For supporting the upper drawer) /2 (without sliding rack)	
	Stylus printer/RS485	Optional (printer or RS 485, either-or)	
	USB Interface	Standard	
Others	Certification	UL,NSF/ANSI 456	

Product appearance and specifications are subject to change without notice